



Atlantic 850



VR850



VRC850

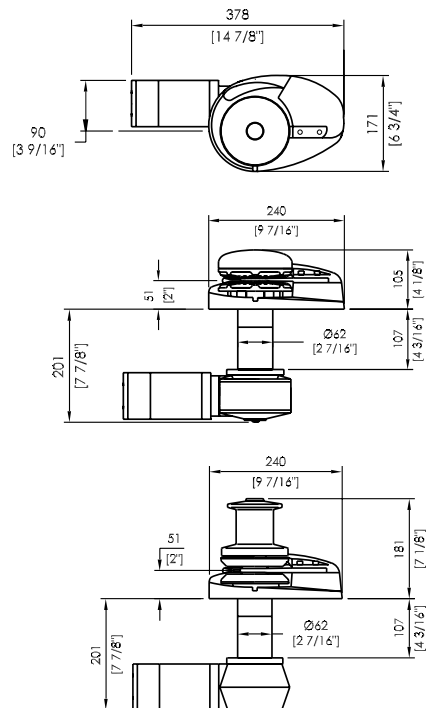

New Inline

Model	VR/VRC850	VR/VRC850
VESSEL LENGTH	8 - 11m 26 - 35ft	8 - 11m 26 - 35ft
POWER SUPPLY (DC)	12/24V	12/24V
MOTOR (Watts)	600	600
MAX LOAD	386kg 850lb	444kg 977lb
WORK LOAD	96kg 212lb	96kg 212lb
AMPS WORK LOAD	80/50	80/50
MAX LINE SPEED	24m/min 77ft/min	24m/min 77ft/min
CHAIN SIZE	6 - 8 - 10mm 1/4 - 5/16 - 3/8"	6 - 8 - 10mm 1/4 - 5/16 - 3/8"
ROPE SIZE	12 - 14 - 16mm 1/2 - 9/16 - 5/8"	12 - 14 - 16mm 1/2 - 9/16 - 5/8"
NET WEIGHT	DC VR 19kg VRC 21kg DC VR42lbs VRC 46lb	DC VR 19kg VRC 21kg DC VR42lbs VRC 46lb
MANUAL OPERATION	MOS (opt)	MOS (opt)

Features

- Rope chain combination gypsy for rope and chain combination or chain only
- Rope Chain Management System (RCMS)
- Quick release integrated swivel chain pipe cover
- Gypsy with capstan (VRC) or gypsy with low profile clutch top arrangement (VR)
- Heavy duty marine grade, dual direction motor in 12 & 24V DC
- Luxury chromed finish over marine grade bronze
- Independent gypsy and capstan operation
- Capstan model features heavy duty knurled finish for increased grip
- Self aligning gearbox/adaptor
- Stainless steel shaft
- Cone clutch/brake
- Stainless steel mounting bolts
- Shaft seal
- Lubricating grease nipple
- Clutch release handle
- Installation/Operation booklet



Options

- Inline drive
- Manual Operation System (MOS)
- Traditional polished bronze finish
- Extra deck clearance kit for any deck thickness
- Full range of accessories including chain, rope, anchors, anchor roller, chain stoppers, snubber kits & devil claws
- Electric operating options & accessories
- Auto anchor



Muir Atlantic 850 Inline