

THX 802 & THX 1602 Thru-Hull Light Lumishore EOS Full Colour Change light Installation and Operating Guide

Congratulations! You have purchased a LUMISHORE advanced technology underwater light. Every care has been taken to ensure your Thru-Hull light arrives in perfect condition, so please enjoy the ultimate experience in underwater lighting.

LUMISHORE Thru-Hull high intensity lights are designed for those owners who prefer the integrity of a thru-hull installation in a light that employs the most powerful, efficient and cost effective underwater LED lighting on the market today. The LUMISHORE Thru-Hull is suitable for many sizes and types of watercraft, including Sports Boats, Cruisers, Yachts and Super Yachts. LUMISHORE Thru-Hull LED lights come with a compact electronic driver module to ensure trouble free operation for years to come.

Please read the following pages before attempting installation to ensure complete understanding of the LUMISHORE LED lights.

BEFORE YOU START

- **High Intensity LED light – Do not stare into the LED module at close proximity.**
- Always ensure that the vessel's power source and battery are disconnected or isolated prior to installation
- A qualified professional should carry out both the electrical and mechanical installation. If in doubt please contact LUMISHORE; Refer to product support section
- The Driver supplies voltage and current to the Thru-Hull lights. **Under no circumstances should the light cable be cut and connected directly to voltage**
- Always use a suitable fuse or circuit breaker to protect the complete system. Each light to be individually fused.
- The Thru-Hull maybe installed into GRP (Glass Reinforced Plastic or Fibreglass) and wooden hulls.
- For metal hull or carbon fibre installations an isolation kit will be required.
- The light should be installed 6" - 10" (150-250mm) below the minimum load waterline.
- For best results install the lights between 2.5ft (0.8m) and 6.5ft (2m) apart.
- Never try to install or remove light with the vessel in the water.
- Lights should not be exposed to any temperatures in excess of 150°F (65°C). For example, next to hot engine components or where exhaust emissions could be expelled onto the light while underwater.
- Do not over tighten the retaining bolts. A force of **3Nm** on each bolt should not be exceeded.
- All LUMISHORE products should have a bonding to the DC system via bonding strap for galvanic protection.
- Choose a location - The light must be installed onto a flat (not curved) surface. Mount on transom or side hull only.

The following components should be used;

- Fuse (1 per light)
- Waterproof junction box
- Power Relay
- EOS Controller
- Power cable - See cable gauge guide for more information
- Power Switch

The following tools will be required;

- Hand Drill
- Screwdriver (Cross head)
- Appropriate Sealant (e.g. 3M 4200)
- Cleaning rags
- Holesaw - Refer to holesaw size on page 8



All connections need to be made waterproof. Use a suitable junction box or waterproof connectors.

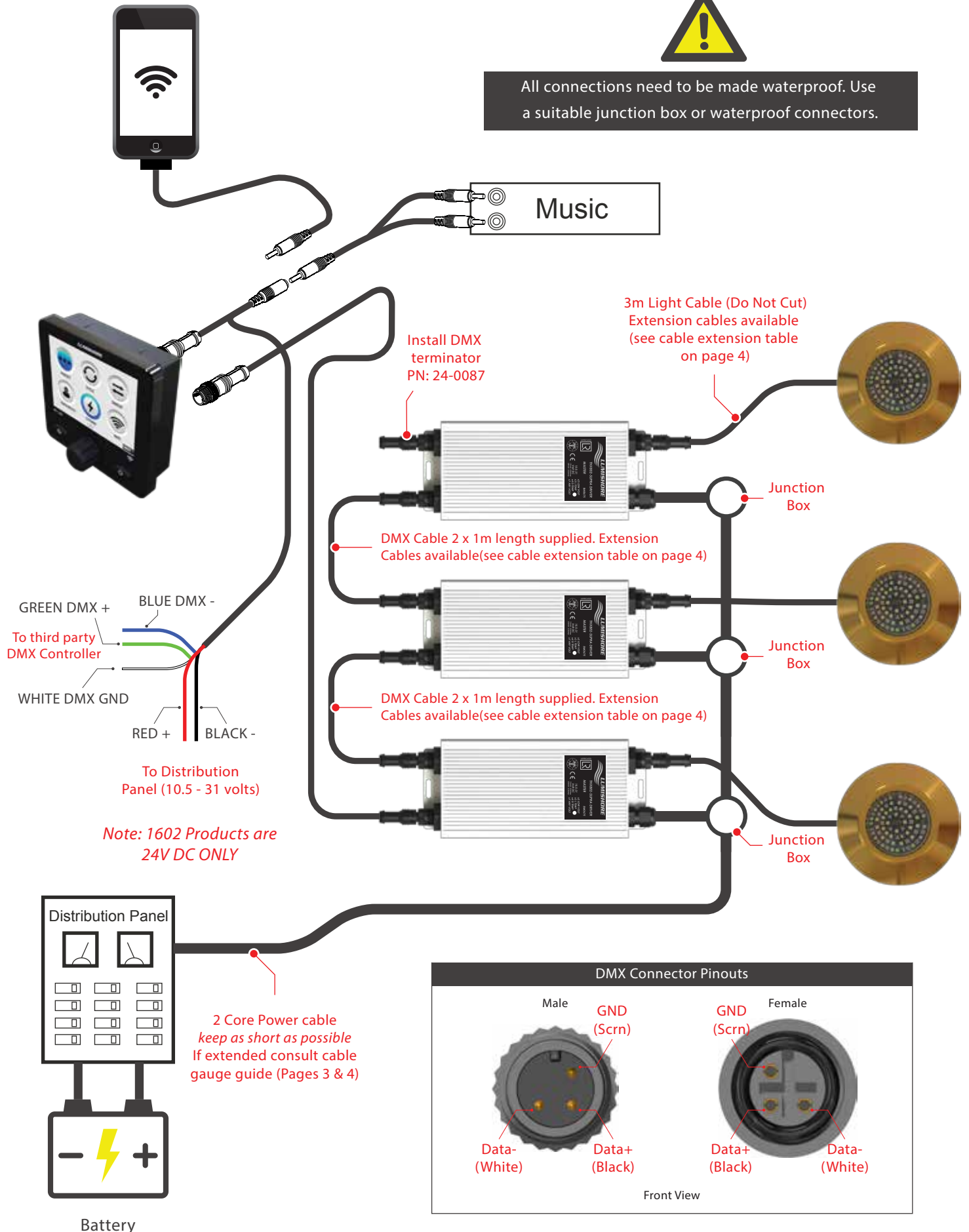

It is important to use the correct cable gauge for the installation. This can be split into two sections.

First work out the gauge required from the power source to the junction box, second work out the minimum gauge needed from the junction box to the lights – these tables are given on page 4.

First, calculate the cable gauge required from the power source to the junction box. The method for doing this is:

1. Calculate the TOTAL CURRENT IN AMPS of the circuit. i.e. number of lights x max current at chosen voltage
2. Find circuit LENGTH IN FEET (or metres) along the left side of the chart. Note that the total length of the circuit is the ROUNDTRIP distance from power source (usually the battery) to the junction box **and back**.
3. Read off the cable gauge required for the TOTAL CURRENT for the circuit length.

3% VOLTAGE DROP	CURRENT FLOW IN AMPS	Cable Gauge (AWG) for 3% Voltage Drop															
		0 to 6 ft	10 ft	15 ft	20 ft	25 ft	30 ft	40 ft	50 ft	60 ft	70 ft	80 ft	90 ft	100 ft	110 ft	120 ft	130 ft
Critical	200A	2/0															
	150A	1															
	120A	2															
	100A	4															
	90A	4															
	80A	4															
	70A	6	8	4													
	60A	6	4	2													
	50A	6	4	2													
	40A	8	6	4	2												
	30A	10	8	6	4	2											
	25A	12	10	8	6	4	2										
	20A	14	12	10	8	6	4	2									
	15A	14	12	10	8	6	4	2									
	10A	16	14	12	10	8	6	4	2								
	5A	16	14	12	10	8	6	4	2								

The DMX cable can be extended, contact your dealer for details of light extension cables.

DMX Extension	Part Number
1m	24-0077
5m	24-0078
15m	24-0099

The light power cable can be extended, however the correct cable gauge should be used. See the tables below.

The tables below give the **minimum** cable gauge required depending on the supply voltage, and distance from the power source to the lights. Please ensure that the correct cable gauge is used in the installation

Note: The cable distance there and back has been taken into consideration in these calculations.

Model	Gauge	Length of Cable	
		12V	24V
THX802	14AWG	Do Not Extend	32ft
THX1602	14AWG	N/A	30ft

Fuse Table

Model	Fuse Rating	
	12V	24V
THX802	15A	7.5A
THX1602	N/A	10A

AWG to Metric conversion table

AWG Size	Cross sectional Area	Cable diameter
18	1mm ²	0.8mm
16	1.3mm ²	1.3mm
14	2.0mm ²	1.6mm
12	3.3mm ²	2.0mm
10	5.2mm ²	2.5mm
8	8.3mm ²	3.2mm
6	13mm ²	4.1mm
4	20mm ²	5.1mm
2	33mm ²	6.5mm



Each light must be individually fused

Bonding Attention: Failure to bond the lights properly and maintain the appropriate protection will invalidate the LUMISHORE warranty.

LUMISHORE lights should be connected to the vessel's DC Bonding system to ensure protection from electrolytic / galvanic corrosion. All bonding connections should be fully checked prior to returning the vessel to the water. LUMISHORE lights have integrated circuitry to protect lights from external issues, but these are dependent upon correct bonding.

Installation into a metal or carbon fibre hull requires an isolation sleeve kit.

Metal or Carbon Fibre Hull Isolation Kit

Model	Part Number
THX802	60-0208
THX1602	60-0209

Installation Considerations:

- **DO NOT CUT THE LIGHT CABLE**
- Location - Positioning will be dependent on both external and internal obstacles; consideration should be given to installation wiring and internal access within the vessel. Ideally the light modules should be installed 6" to 10" (150-250mm) below the water line and spaced between 2.5ft to 6.5ft (0.8-2m) apart.
- Select a flat surface; make sure that both the internal and external surfaces of the hull are even and parallel. It may be necessary to sand or grind the surface.
- A hole will be drilled to allow the Thru-Hull light to be inserted; care must be taken to ensure there is unrestricted access inside the hull
- The light is temperature sensitive and must not be located close to the exhaust or other heat sources.
- If multiple lights are installed, each light should be evenly spaced to ensure the best water illumination. The number of lights and the spacing on your vessel will depend on a few factors: vessel size, location of lights and water clarity.

Light Unit

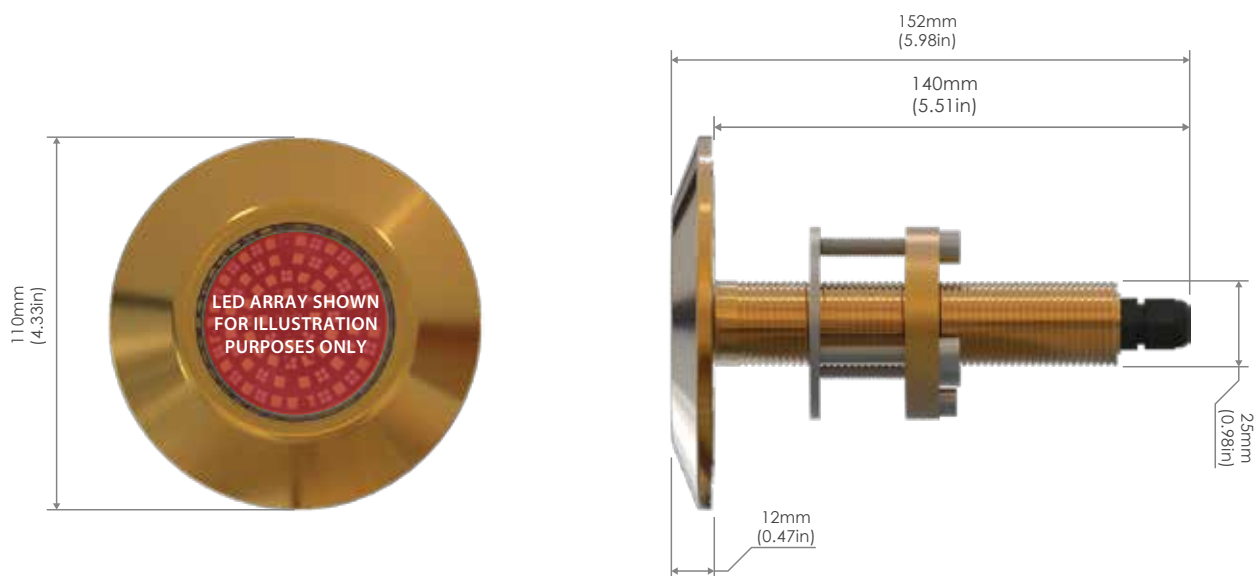

DC Driver

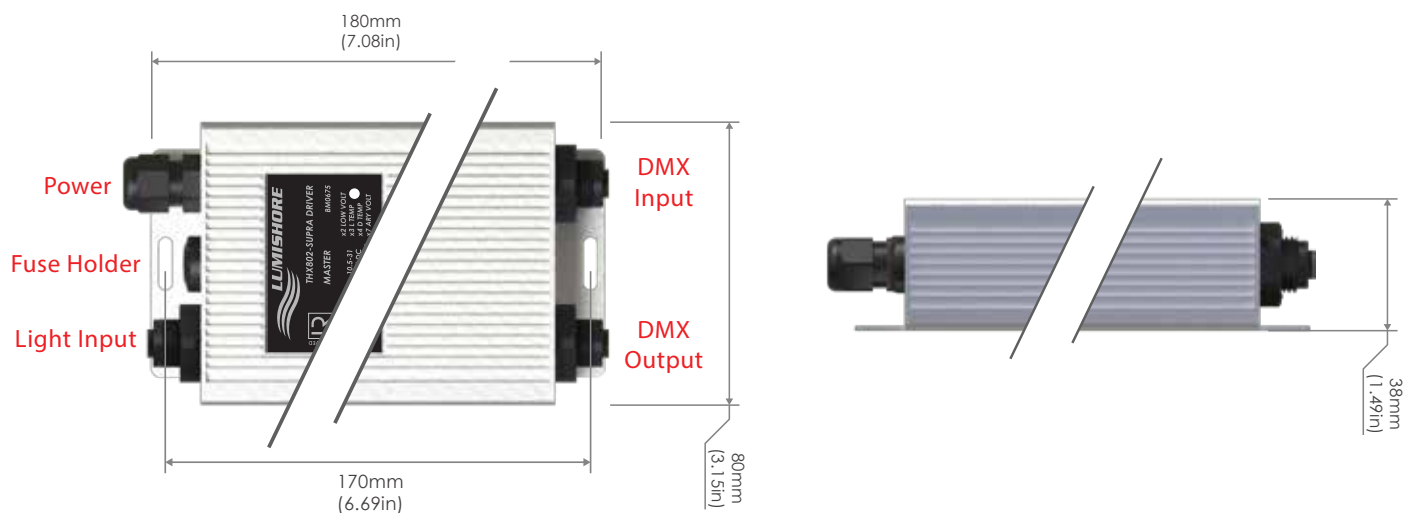

Light Unit

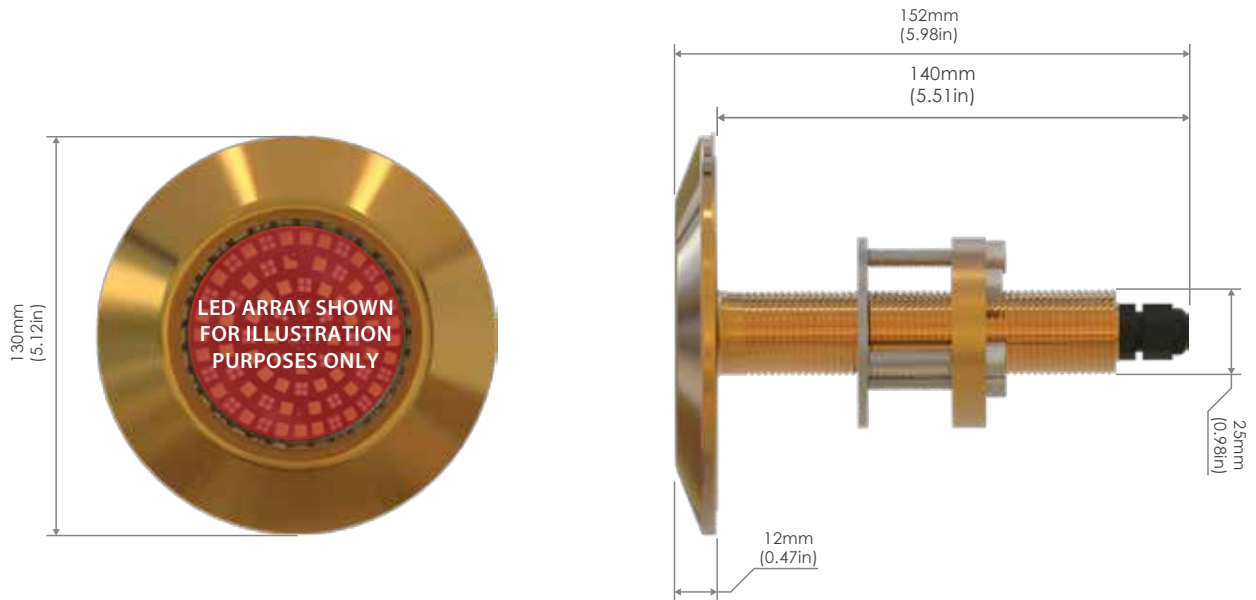

DC Driver

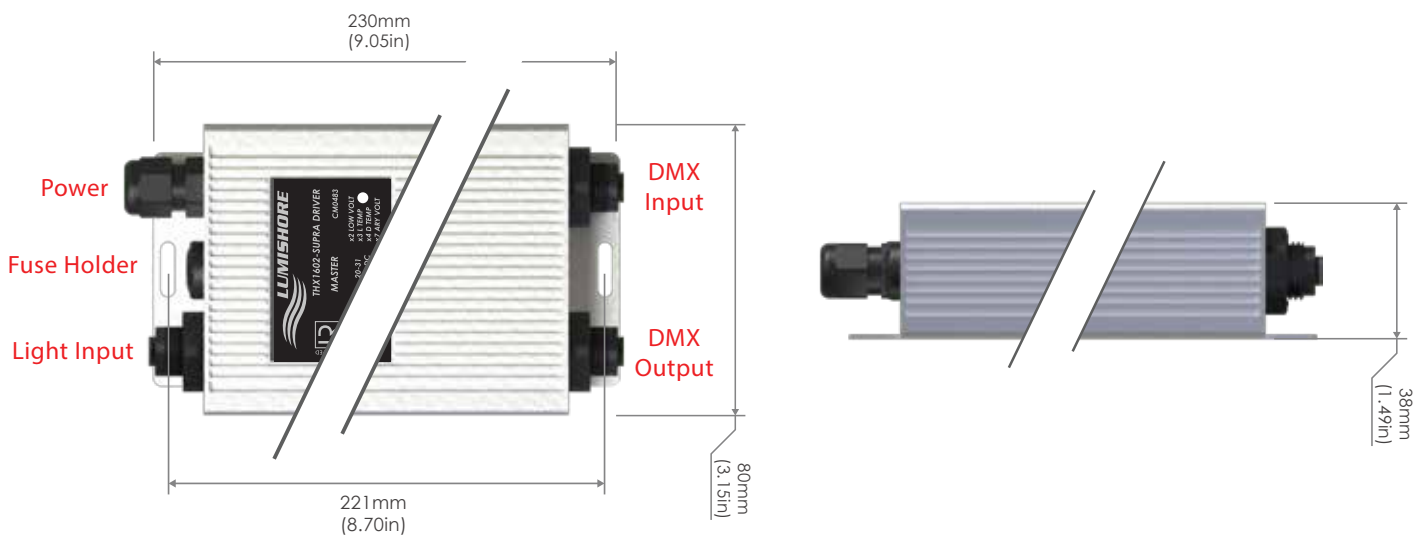

Tools Required



5mm Allen Wrench

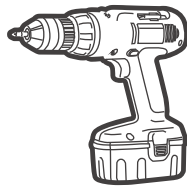

Drill/Driver

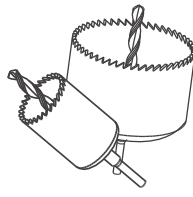

Holesaw



Marine Sealant
(Use only 3M 4200)

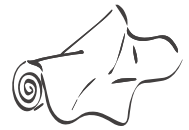

Rags for clean-up

1. Measure the position of the lights on a flat part of the hull. Mark carefully, and double-check for internal obstacles.
2. Check the required hole size against the table below. Drill a perpendicular hole through the hull using an appropriate cutter for the hull material.

Model	Hole Size	Hole Size W/Delrin Sleeve
THX 802	27mm (1.0625")	32mm (1.25")
THX 1602	27mm (1.0625")	32mm (1.25")

3. The exposed inner hull surface must be properly sealed to prevent water intrusion into the hull before the Thru-Hull is secured in place.
4. Before inserting the Thru-Hull light ensure that the hull surface is free from dirt and grease and remove any existing anti-foul from the hull surface.



Note: Do not use an alcohol-based solvent as this may have an adverse effect on the sealant

5. Using an approved adhesive (3M 4200 Marine (recommended) or similar), apply liberally a continuous bead of sealant around the entire circumference of the sealant groove, on the base of the stem and on the shaft of the Thru-Hull.
6. Feed the connector and cable through the hole in the hull avoiding any strain on the cable. Gently insert the stem of the Thru-Hull light assembly through the hole in the hull.
7. Apply even pressure with a slight circular motion until the Thru-Hull is flush with the hull surface. **Ensure the light is orientated correctly. See page 9 for more information.**
8. From inside the vessel, feed the supplied washer down the shaft of the Thru-Hull fitting. Screw the locking nut in place and tighten the retaining bolts so that they are hand tight (less than 1Nm) - **Do not tighten fully at this stage, excess pressure will push all of the sealant out.**
9. Remove excess sealant that is squeezed from behind the light with a rag.
10. Allow the sealant to cure according to the sealant manufacturer's instructions. Once fully cured, using a 5mm Allen wrench, re-tighten each retaining bolt (force less than **3Nm**). **Care should be taken not to exceed this force as damage to the light module or hull of the vessel may occur.**
11. Attach the vessel's bonding protection to the bonding bolt on the locking ring.

Ensure that each light module has correct vertical and horizontal alignment with the hull, and that the correct orientation of the light module is achieved (refer to the module below).

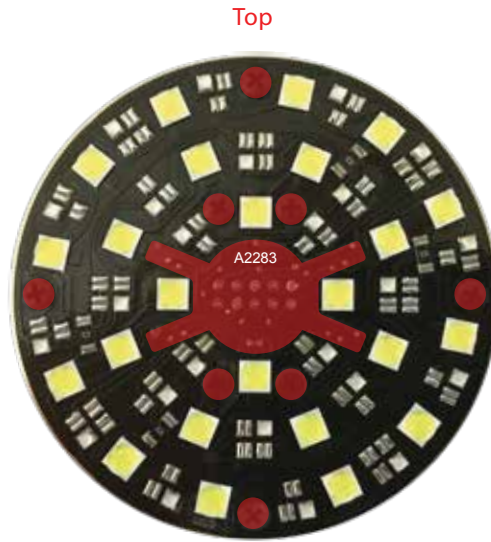

Front View

Driver Installation			
Model	Driver Type	Max Current (12V DC)	Max Current (24V DC)
THX 802	DC	8.8A	4.4A
THX 1602	DC	N/A	6.5A

1. Select a suitable location to mount the driver. This should be in a **dry** location, with free airflow around the driver.
2. The driver should be mounted onto an flat surface.
3. Use the mounting holes at either end of the case to secure the driver.
4. Each driver must be connected to an On/Off switch. Due to the high currents involved it is recommended that a relay is used.
5. Each driver must have its own fuse/RCD breaker.
6. Refer to the wiring examples in this manual for further guidance.
7. Plug the light into the driver
8. Refer to the EOS controller manual for setup instructions.



Ensure correct electrical polarity. Incorrect installation will invalidate warranty!

Note: Care must be taken when plugging in the light to the driver module as the connectors are keyed and if forced may bend/break a pin on the connector.



The underwater lighting system should always be tested before the boat goes back in the water. Check that each light comes on and all lights change in sequence as per the system operation section above. See the problem solving guide for advice on resolving any issues you may have. Once the boat is back in the water check for any water ingress around the installed lights. Check again after several hours. Water ingress should be dealt with immediately. The lights should be checked several times over the first 24hrs and periodically after that to ensure installation is satisfactory.

Maintenance and Cleaning

The locking nut and retaining bolts should be inspected on a regular basis to ensure they are kept tight. LUMISHORE recommends general inspection of the light module, driver and cable attachments every month.

LUMISHORE lights require simple cleaning. Lights should be checked often to ensure the light body and lens area are free from sea growth. In the event that your light requires cleaning, we recommend the use of a soft cloth or soft bristled brush. The glass should be kept clean with a plastic scraper or soft brush. Regular cleaning of the lens will ensure that the light module delivers maximum optical output. DO NOT use an abrasive cloth or cleaning agent as permanent damage to the lens may occur.

DO NOT use any abrasive cleaning materials as these may damage the body of the light.

DO NOT use any cleaning fluids that contain solvents, acids or alkalis.

DO NOT clean using pressure washing or sandblasting equipment.

Slight discolouration of body may occur over life. This does not affect performance, and is not subject to warranty.

Due to nature and high build quality it may on rare occasions be possible to see small levels of condensation, this is normal for high power LEDs and will disappear after cooling and does not harm operation in any way.

No chemicals, cleaners, chemical sprays or sandblasting should ever be applied / used on lights — this will negate warranty

To prolong device lifetime and prevent marine growth build up, a good quality anti-fouling system must be used to coat the external body of the device. This should be renewed regularly.

Product Support

If you have questions or comments, please e-mail info@lumishore.com or call USA (941) 405-3302, United Kingdom +44(0)208 144 1694, or France +33(0)493 582 537.

Warranty

LUMISHORE Ltd warrants the Thru-Hull lighting system to be free from defects in workmanship for a period of 3 years, starting from the date of original purchase. Should your lighting system have a problem during this period, please contact your dealer as soon as you become aware of the defect.

Misuse, abuse, improper installation, neglect, improper shipping, damage caused by disasters (e.g. fire, flood and lightning), installation by unqualified personnel, unauthorized repair or modification will void this warranty. For the avoidance of confusion and doubt, non compliance with all installation, maintenance and operating instructions in this document constitute non conformance with warranty terms.

Full warranty details are available at www.lumishore.com.

Troubleshooting

In the event of one or more of the lights not lighting up then check the LED status on the driver. The LED will either be continually ON (healthy), OFF (no power to driver) or flashing. Please refer to the table below for what the number of flashes means and what action to take.

LED Status	Meaning	Action to take / Things to check
No LED light on driver	No power to driver	Check fuse / breaker Check connections Check voltage at input to driver connections
Solid LED	Power On	Driver is receiving voltage and operating properly Check the controller is operating correctly Check EOS/DMX connections Check intensity is turned up
Flashing 2 times	Low input voltage to driver	Check power connections or battery voltage
Flashing 3 times	Light temp too high	Could happen when light is out of water or next to exhaust
Flashing 4 times	Driver temp too high	Driver is mounted too close to an engine or exhaust
Flashing 7 times	LED array voltage out of range	Check the connections between light and driver Check light in each colour to determine if all colours are working
Flashing 8 times	Light not detected	Light is not connected or cable is cut or pinched Light has been connected incorrectly to the driver
Continuous rapid flashing	Driver program corrupt	Reset driver by switching off power for 1 minute, and then switching on again Contact LUMISHORE if problem persists

In the event of an issue then:

1. Check the operation of the light and driver with only that light and driver powered
2. If the light is still not operational then swap the driver with the flashing LED with a driver which is known to be working and re-test the light
3. Test the driver with a known good light
4. This will determine if the issue is with the light or the driver
5. Record the serial numbers of both the light and the driver and contact your local dealer

Thank you!

For purchasing LUMISHORE lights