

FILLING AND PURGING THE SYSTEM

Read First

NOTICE

If system is fitted with SeaStar Power Assist, please refer to your Power Assist Installation Manual for bleeding instructions.

These instructions show how to fill and purge a Single Station Front Mount Cylinder System. For twin station and/or twin cylinder filling and purging instructions refer to instructions on page 39 first and then proceed with instructions on this page.

This procedure requires two people. One person may not be able to remove all the air from the system which will result in spongy, unresponsive steering.

During the entire filling procedure, oil **must** be visible in the filler tube. **DO NOT** allow the oil level to disappear into the helm pump, as this may introduce air into the system and increase your filling time.

NOTICE

If using a Liquid Tie bar Valve, part # HA5471-2, please refer to the bleeding instructions included with the liquid tie bar valve.

Hydraulic Oil Requirements

2 bottles (2 quarts or liters) for single station and single cylinder systems.
1 additional bottle for each additional helm, cylinder, or auto pilot.

NOTICE

Oil can be re-used if filtered through a fine mesh screen such as used for gasoline. If unable to filter oil, an additional bottle of oil is required.

NOTICE

“Bleeder” may refer to cylinders fitted with bleed tee fittings or bleed screws. If fitted with bleed tee fitting, open bleeder by unscrewing bleed nipple nut two turns.

NOTICE

Filling the helm full of oil can be done faster if oil is poured into the helm prior to connecting filler tube and oil bottle to the helm. Part # HA5438.

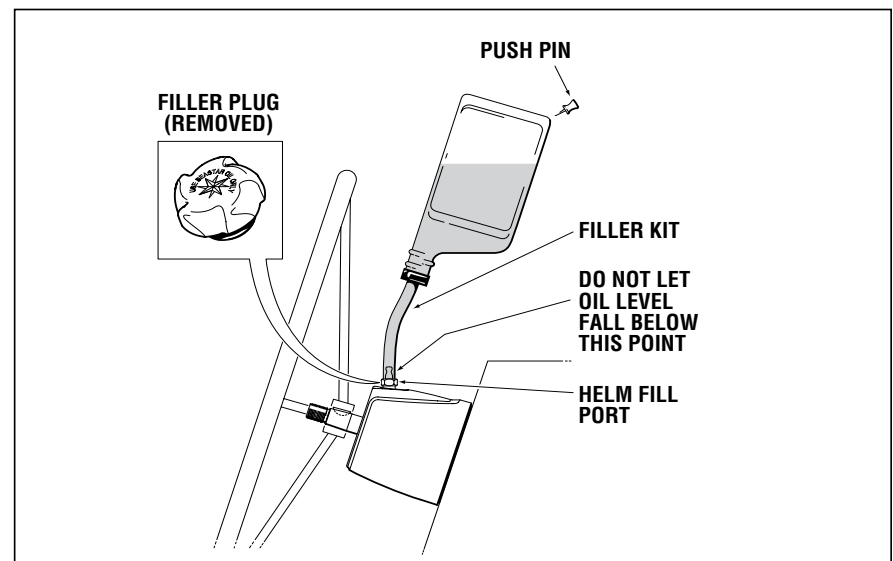

Figure 36. Optional Filler Kit Part # HA5438

NOTICE

In the following pages you are instructed to hold cylinder body with your hand, if the cylinder is mounted to an engine, use the engine to hold the body in position.

HYDRAULIC STEERING

FILLING AND PURGING

Hydraulic Fluid

⚠ WARNING

ANY NON-APPROVED FLUID MAY CAUSE SERIOUS DAMAGE TO THE STEERING SYSTEM RESULTING IN POSSIBLE LOSS OF STEERING, CAUSING PROPERTY DAMAGE, PERSONAL INJURY AND/OR DEATH.

Due to recent upgrades in our steering system components, SeaStar Solutions recommends use of SeaStar Steering Fluid **ONLY** in our hydraulic steering systems. SeaStar Steering Systems have been engineered and validated using our proprietary SeaStar Hydraulic Steering Fluid. SeaStar Steering fluid is engineered with special additive package that contains anti-foaming and anti-rusting agents, anti-oxidants, viscosity stabilizers, corrosion inhibitors, wear additives as well as water emulsification additives. It is highly recommend that SeaStar Steering Fluid be used to ensure optimum system performance and safety.

Use of any non-approved fluid may result in the following;

- higher steering effort, particularly at ambient or lower temperatures and/or over time due to oil degradation and breakdown
- increased steering slip and/or drift resulting in lost motion
- foaming or air entrapment causing a bumpy feel during steering
- high rates of moisture absorption causing internal component corrosion
- scratched steering cylinder bores and shafts due to contamination or elevated wear rates
- seal degradation – incompatibility with various proprietary seal compounds used in our products.

In an emergency, SeaStar EPS Fluid, any MD-3/4 rated ATF or MIL-PRF-5606H equivalent fluid that is filtered through a fine mesh screen can be used. The system **MUST** be thoroughly flushed as soon as possible with genuine SeaStar Steering Fluid after using an emergency fluid.

In an **EXTREME** emergency, any non-toxic, non-flammable fluid that is filtered through a fine mesh screen may provide temporary steering.

Use of non-standard fluids will require an immediate and complete system flush using approved fluids, by an approved steering technician.

⚠ WARNING

NEVER FILL OR MIX BRAKE FLUIDS, TRIGYCIDES OR POLYALKYLENE GLYCOLS WITHIN A HYDRAULIC STEERING SYSTEM.

NOTICE

SeaStar Hydraulic Steering Fluid can be used in Hynautic, BayStar and BayStar Plus steering systems.

NOTICE

Help protect your boating environment by ensuring that all used oil is disposed of properly.

Fill Plugs for SeaStar Helms

VENT PLUG - Part No. HP6126

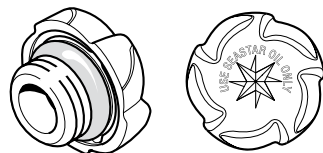

SUPPLIED WITH SEASTAR HELM PUMP

- MUST BE USED WITH HELM PUMP ON ALL SINGLE STEERING STATION SYSTEMS.
- MUST BE USED ON UPPERMOST HELM PUMP ON MULTI STEERING STATION SYSTEMS.

NON-VENT PLUG - Part No. HP6000

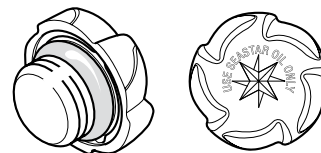

- MUST BE USED ON ALL HELM PUMPS OTHER THAN UPPERMOST HELM PUMP ON MULTI STEERING STATION SYSTEMS.
- THIS NON-VENT PLUG IS SUPPLIED WITH ADDITIONAL STATION FITTING KIT NO. HF5501 AND HF5502.

Figure 37.

Single Station One Cylinder

Step 1

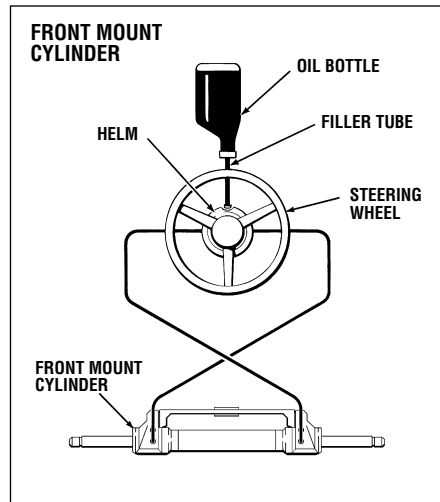

- Screw the threaded end of the filler tube into the helm filler port.
- Remove the cap from the oil bottle and holding upright screw into the filler tube bottle cap. Poke hole in the bottom of the bottle.
- Fill the helm pump full of hydraulic oil so that it is visible in the filler tube. Oil should always be visible in the filler tube. Use the next bottle of fluid at any time during the procedure in order to maintain the oil level. **DO NOT** proceed with step two until helm is full.

Step 2

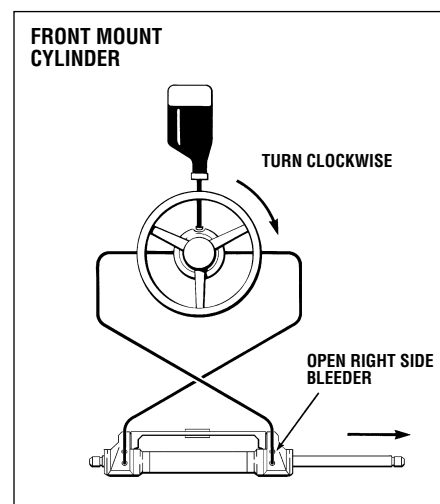

- Turn the steering wheel clockwise until the cylinder rod is fully extended on the right side of the cylinder.
- Open right side bleeder.

Step 3

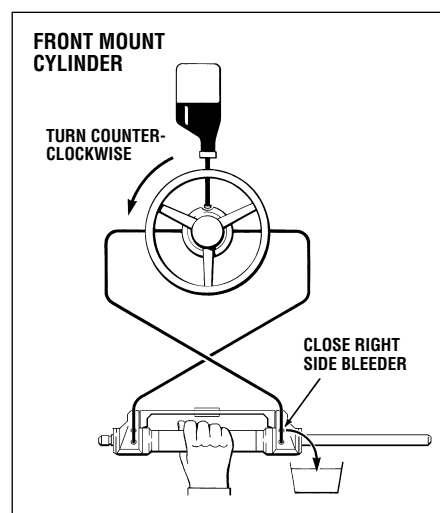

- Holding the cylinder body (Front Mount cylinder) or rod (Side Mount cylinder) to prevent the body/rod from moving, turn the steering wheel counter-clockwise until a steady stream of air free oil comes out of the bleeder. (Drain approx. 1/2 bottle of oil or as required).
DO NOT use anything other than your hands to restrain the cylinder body/rod.
- While continuing to turn the wheel close the right side bleeder and let go of the cylinder body/rod.

HYDRAULIC STEERING

FILLING AND PURGING

Step 4

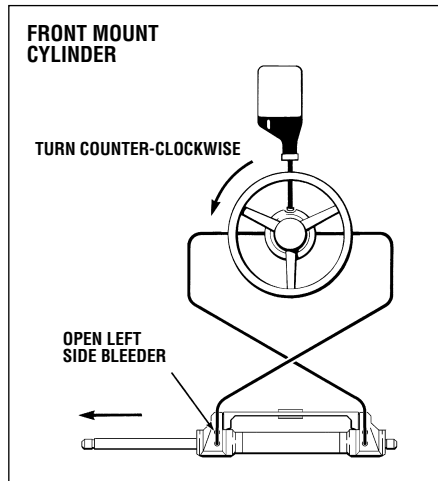

- Continue turning the steering wheel counter-clockwise until the cylinder rod is fully extended to the left. (Steering wheel will come to a stop).
- Open the left bleeder.

Step 5

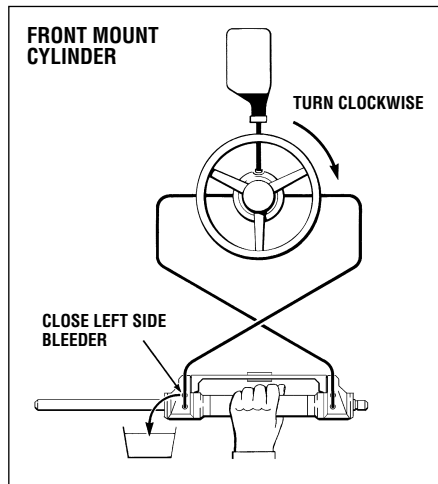

- Holding the cylinder body (Front Mount cylinder) or rod (Side Mount cylinder) to prevent the body/rod from moving, turn the steering wheel clockwise until a steady stream of air free oil comes out of the bleeder.
- While continuing to turn the wheel close the left side bleeder and let go of the cylinder body/rod.

⚠ CAUTION

Prior to operating system, perform Oil Level System Check, refer to page 40.

Number of Steering Wheel Turns

When steering system has been properly bled, steering wheel turns from hard over to hard over will be as shown in the chart.

Helm Displacement	Single Cylinder	Twin Cylinder with Mechanical Tiebar	Twin Cylinder with Liquid Tiebar
1.4	5.90	11.8	5.90
1.7	4.90	9.76	4.90
2.0	4.15	8.30	4.15
2.4	3.45	6.90	3.45
3.0	2.76	5.50	2.76

Twin Station Single Cylinder

Perform steps 1 through 5 at station no. 1. Then repeat steps 1-5 at station no. 2.

Oil requirements 4-5 bottles.

Note: Refer to Oil Level and System Check page 40.

When properly bled, steering wheel turns will be as shown in the chart.

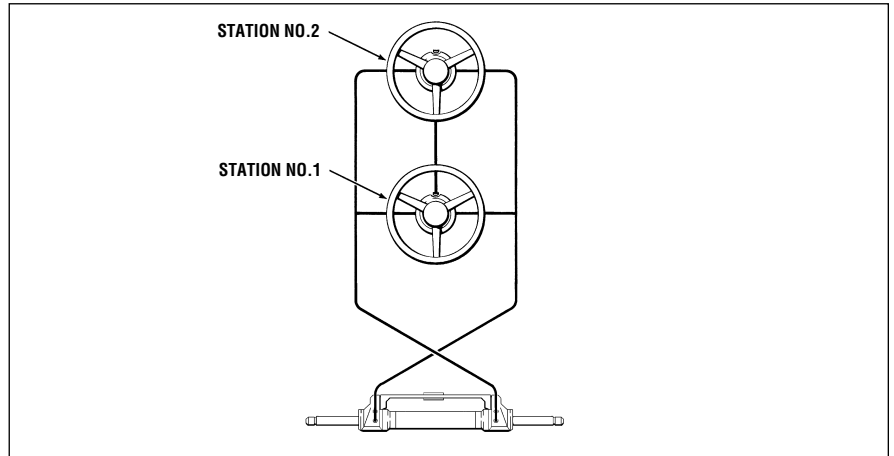

Single Station Twin Cylinder

When performing steps 1 through 5, perform instructions in each step first on cylinder no. 1 and then on cylinder no. 2, before proceeding to the next step. ie: Perform instructions referring to right side of cylinder first on cylinder no. 1 and then on cylinder no. 2.

Oil requirements 4-5 bottles.

Note: Refer to Oil Level and System Check on page 40. Steering wheel turns will be as shown in the chart.

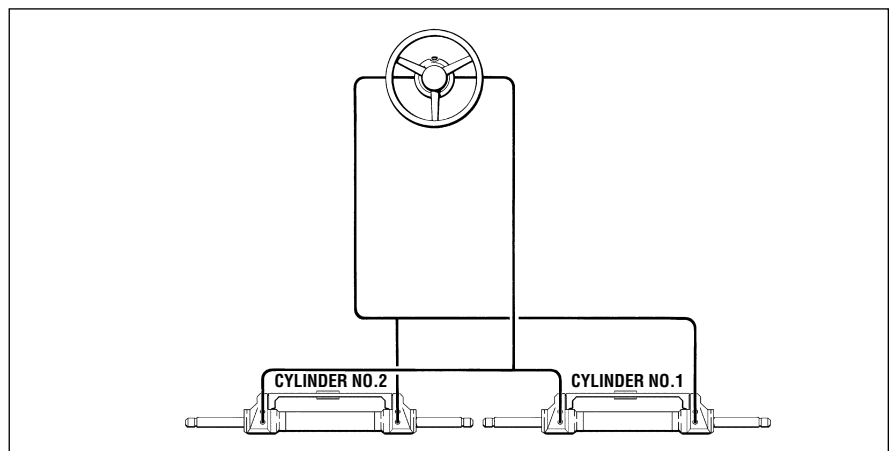

Twin Station Twin Cylinder

Follow same procedure as instructed for single station-twin cylinders, beginning at station no. 1, and repeat entire procedure at station no. 2.

Note: When properly bled, steering wheel turns will be as shown in the chart.

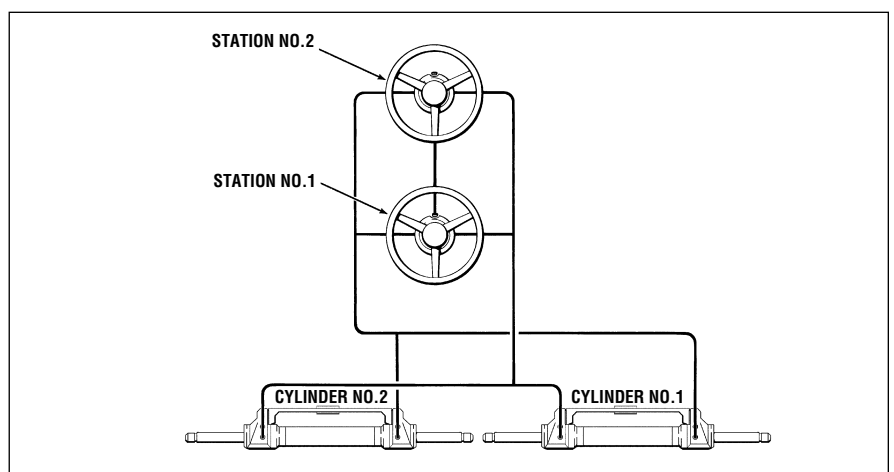

Oil Level and System Check

Step 1 – Oil level Setting

⚠ WARNING The oil level **MUST** be checked and maintained **BEFORE** EACH use to ensure safe steering operation. Failure to adhere to this warning may lead to loss of steering control resulting in persons being ejected from vessel or collision with an obstacle, leading to property damage, personal injury and/or death.

- For helms mounted with the wheel shaft completely horizontal **MUST** be filled to the bottom of filler hole **AT ALL TIMES**. **DO NOT** allow oil level to drop more than 1/4" below filler threads.
- For helms mounted on a 20 degree angle, or, with wheel shaft in the vertical position, oil level should be within 1/2" from the bottom of the filler hole.

NOTICE

*If the helm is overfilled fluid **WILL** leak out of the vent cap.*

Step 2 – System Check

⚠ WARNING The system check **MUST** be completed after installation. Doing so will ensure the safe operation of your steering system and will any fault/leak will show at this time. Failure to adhere to this warning/check may result in the loss of steering control leading to ejection from the vessel, or, collision with an obstacle resulting in property damage, personal injury and/or death.

- Turn steering wheel hard over to hard over to confirm unrestricted movement of the steering system and hoses. Repeat this procedure in ALL trim/tilt positions of the engine(s). If interference occurs, or, hoses are being stretched this **MUST** be removed prior to operating your boat.
- Confirm that engine(s) are deflecting to the proper direction when steering wheel is turned.
- If no interference is noticed, or, any interference is corrected, go to next step.
- Take steering wheel hard over to starboard (any helm can be used on a multi-station boat). Once the wheel reaches its stop point (cylinder is fully stroked out), continue to force the wheel one (1) full turn past stop. Leave wheel in this position while you check all PORT side connections, fittings, seals and hoses for leaks.

NOTICE *This step will NOT harm the system and any noise made during this step should not be considered a fault in the steering system.*

- If leaks are noticed they **MUST** be repaired prior to operating boat. After repair repeat bleeding procedures as outlined in this manual
- Repeat to the Port direction and inspect ALL starboard side connections, fittings, seals and hoses for leaks.

NOTICE *This step will NOT harm the system and any noise made during this step should not be considered a fault in the steering system.*

- If leaks are noticed they **MUST** be repaired prior to operating boat. After repair repeat bleeding procedures as outlined in this manual.

⚠ WARNING

Failure to complete the above noted step or, failure to correct a problem may result in loss of steering control leading to ejection from the vessel or collision with an obstacle resulting in property damage, personal injury and/or death.