**SEASTAR™**

CLASSIC TILT MECHANISM REPLACEMENT, Part #HA6523

⚠ WARNING

This kit is designed to replace the tilting mechanism of a SeaStar Traditional and SeaStar Classic Tilt helms. In ALL cases, use ALL of the mounting hardware, plates and mechanism that are included with this kit. DO NOT re-use any of the older parts off your tilting helm pump.

Tilt Mechanism Removal

1. Remove steering wheel.
2. Remove plastic tilt covers.
3. Locate and remove Socket Head Screw (item 1, figure A, A1 & B1).
4. Tilt Mechanism removal:
 - a. Traditional Tilt helms: Locate and remove the 4 nuts (item 2, figure A) that fasten the tilt mechanism to the helm pump
 - b. Classic Tilt Helms: Locate and remove the two screws (item 2, figure B) that fasten the tilt mechanism to the helm pump.
5. Slide Tilt Mechanism off of helm pump wheel shaft.
6. Traditional Helms ONLY. Locate and remove the three bolts and washers (item 3 and 6, figure A) that fasten the helm plate (item 4, figure A) to the helm pump.
7. Locate and remove the four carriage bolts (item 5, figure A). Discard the helm plate (item 4, figure A) and fasteners as they are not required for installation.

⚠ CAUTION

AT this time the helm pump will NOT be fastened to the dash board. Take appropriate steps to avoid kinking of the steering lines.

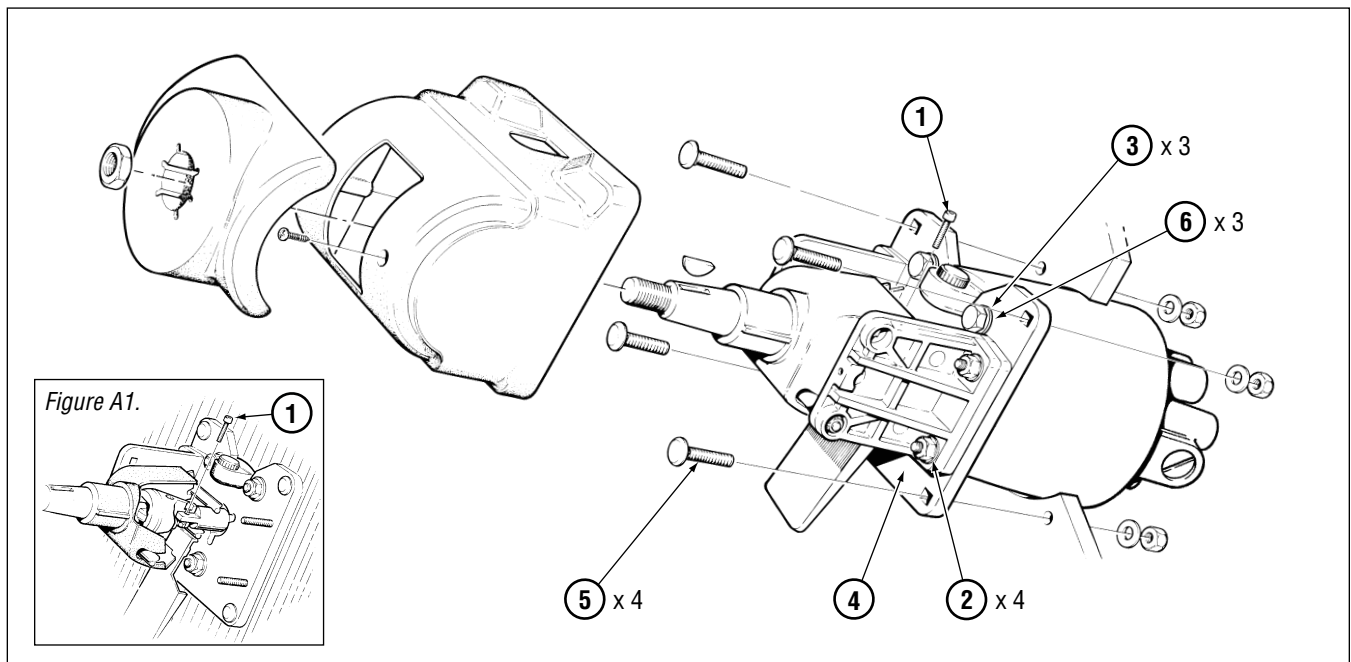
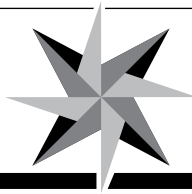

Figure A. Traditional Tilt Helm Mechanism Shown.



Traditional Tilt Helm Mechanism ONLY Replacement Instructions

1. Install the square mounting plate (item 11, figure B) to the dash using the four dash bolts, washers and nuts (items 13, 14 and 15, figure B). Torque nuts (item 15, figure B) to 110 in/lb.
2. Install the helm pump onto the square mounting plate (item 11, figure B) using the bolts and washers provided (items 12 and 16). Torque to 160–180 in/lb.

Classic Tilt & Traditional Tilt Helm Mechanism Replacement Instructions

1. Attach the helm shaft to the tilt mechanism (item 3, figure B) by lining up the coupling slot with the helm shaft tongue and secure with the one 10–24 NC x 7/8" bolt (item 1, figure B). Torque **BOTH** bolts to 27–31 in/lb. (Refer to figure B1).
2. Install and tighten the two PHMS 5/16" NC x 3/4" screws (item 2, figure B) and the star washers (item 4, figure B) to secure the tilt mechanism to the dash plate. Torque to 160–180 in/lb.
3. Install the boot latch (item 5, figure B) onto the tilt latch of the tilt mechanism.
4. Fit the upper bezel (item 6, figure B) into the lower bezel (item 7, figure B) and position these two parts over the tilt mechanism and latch boot. Install the 7 x BHSCS 8–32 x 1/2" SS (item 8, figure B) screws into the positions shown.
5. Grease steering shaft with good quality marine grade grease.
6. Install the woodruff key (item 9, figure B) and wheel shaft nut (item 10, figure B). Tighten steering wheel shaft nut prior to continuing with installation instructions. Torque wheel shaft nut to 150 in/lb. **DO NOT** exceed 200 in/lb.
7. Confirm proper function of the tilt mechanism by performing the following points.
 - Push tilt latch forward to 'unlock' the tilt mechanism.
 - Check **ALL** positions of the tilt and confirm that the latch 'locks' in place for each position, tilt lever will click back into the locked position.

⚠ WARNING

Use self-locking fasteners provided **ONLY**; substituting non-self locking fasteners can result in loosening or separation of equipment leading to loss of steering control causing property damage and/or personal injury or death

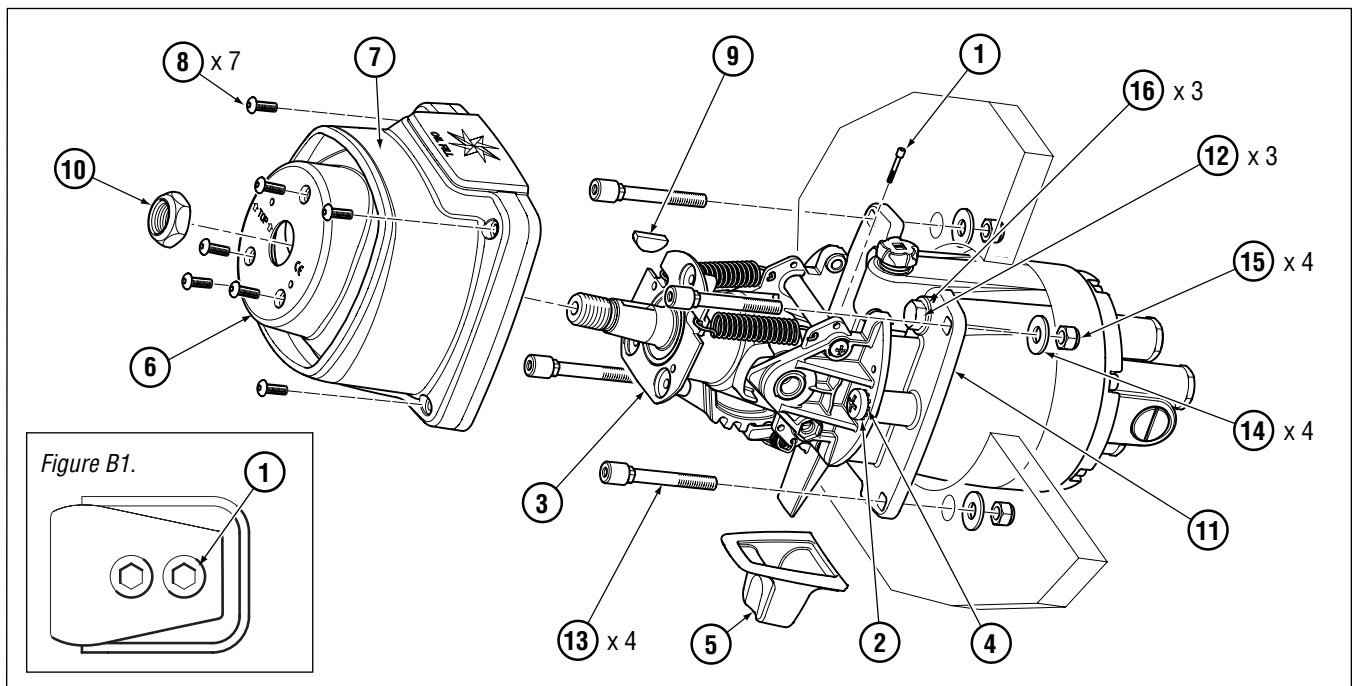

Figure B. Classic Tilt Mechanism Shown.